

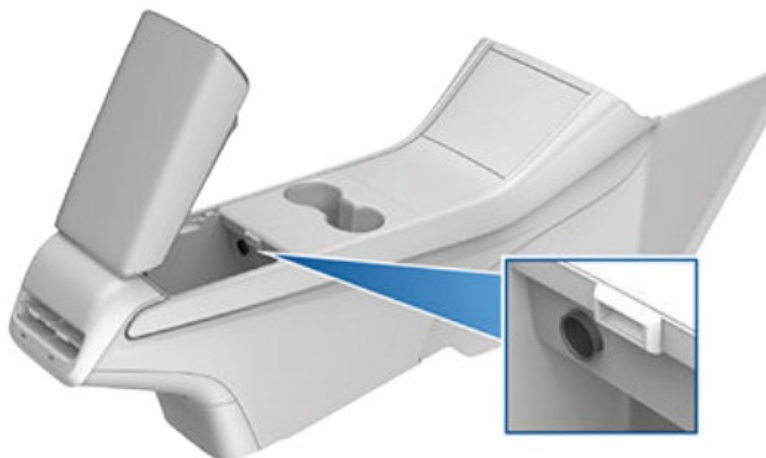

# Model 3 12V Power Circuit for Third-Party Accessories

All Model 3 vehicles are equipped with a 12V power socket which is located in the center console's rear compartment (Figure 1).



**Figure 1**

The purpose of this power socket is to provide a switched power source that reduces the risk of vehicle damage due to improperly installed third-party equipment. Only when a more permanent installation is required should the circuit that feeds the power socket be used. This document is intended to help locate the recommended power circuit, and provides informational support to individuals looking to safely splice into the 12V power circuit.

**⚠ CAUTION:** Splicing into the 12V system is done solely at the user's risk and can result in increased draining of, or potential damage to, the vehicle or 12V battery. Potential effects of modifying Model 3 with third-party components can include, but are not limited to, reduced driving range and increased electromagnetic interference (EMI).

**⚠ CAUTION:** Always refer to the Service Manual for the most up-to-date instructions on disconnecting and reconnecting 12V power and removing and installing center console trim components. The instructions in this document may not be applicable to the particular vehicle you are working on due to build date, configuration changes, market region, etc.

**📄 NOTE:** Tesla does not endorse the use of third-party equipment and does not accept any responsibility for any damage incurred from installing non-OEM equipment.

**📄 NOTE:** Tesla employees are not permitted to install, or assist with the installation of, third-party equipment.

## Accessing the 12V Power Circuit

Refer to the following steps for how to access the power circuit within the center console.

**⚠ CAUTION:** 12V power must be disconnected as detailed in the Service Manual before splicing into the power circuit; do not attempt to splice into the power circuit before performing the 12V disconnect procedure.

1. On both sides of the center console, use a trim tool to release the clips that attach the center console decor trim to the center console, and then remove the decor trim (Figure 2).

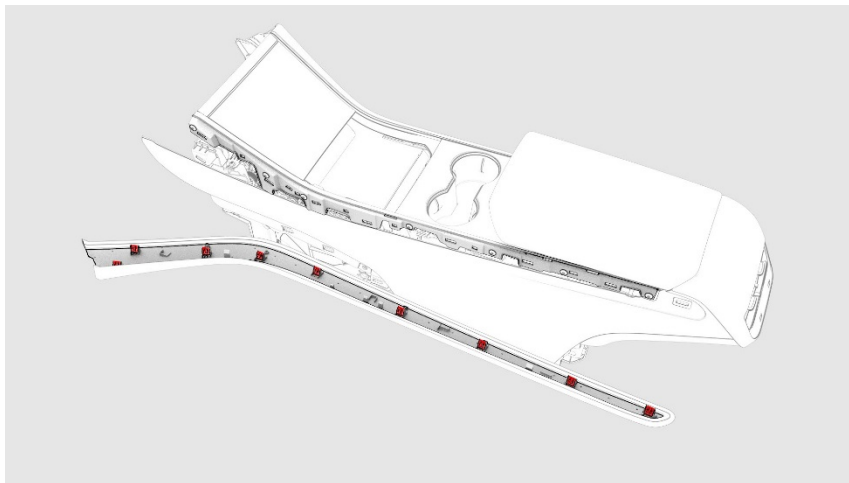

**Figure 2 – LH side shown; RH similar**

2. On both sides of the center console, remove the screws (x7) (Figure 3) and release the tabs that attach the bracket to the center console. Remove both brackets from the center console.

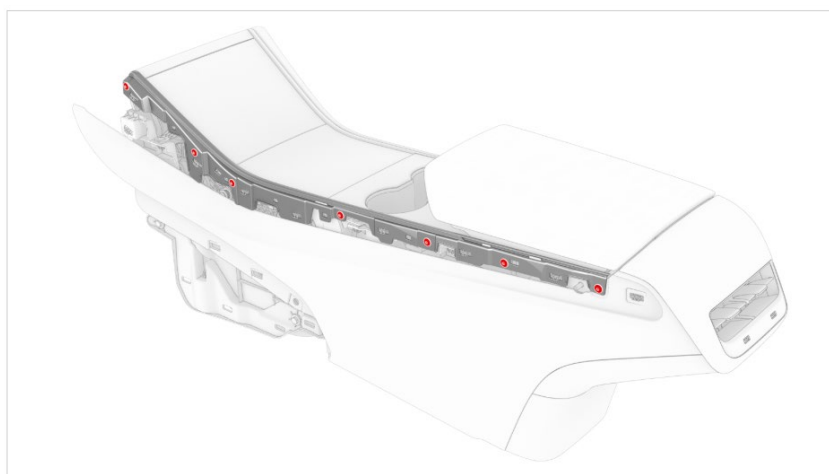

**Figure 3 – LH side shown; RH similar**

3. Lift the armrest to access the rear center console compartment.

- Carefully lift up the cup holder décor trim to release the clips that attach it to the center console (Figure 4).

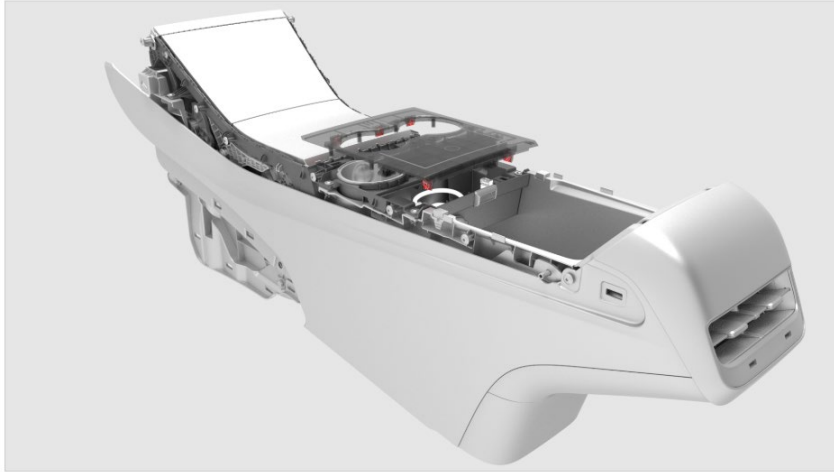

**Figure 4**

- Disconnect the electrical connector from the security body controller module (Figure 5), and then remove the décor trim from the center console.

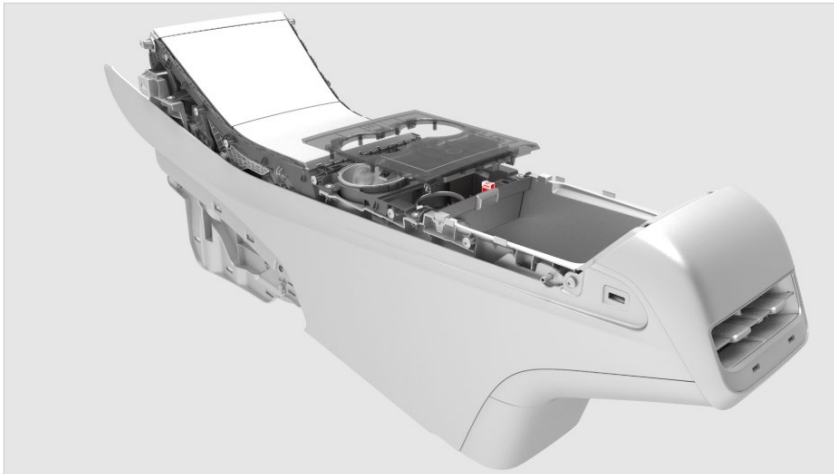

**Figure 5**

## Disconnecting 12V Power

12V power must be disconnected before splicing into the power circuit. Refer to Service Manual procedure 17010200 for instructions on disconnecting 12V power.

**⚠ CAUTION:** Failure to properly disconnect 12V power prior to splicing into the 12V power circuit can result in damage to the vehicle or the 12V battery. Tesla is not responsible for any damage to the vehicle or 12V battery.

## Splicing Into the 12V Power Circuit

Tesla recommends to make a T-junction connection between the 12V auxiliary socket and its electrical connector (Figure 6). This method is preferred because the original vehicle wiring is not compromised.

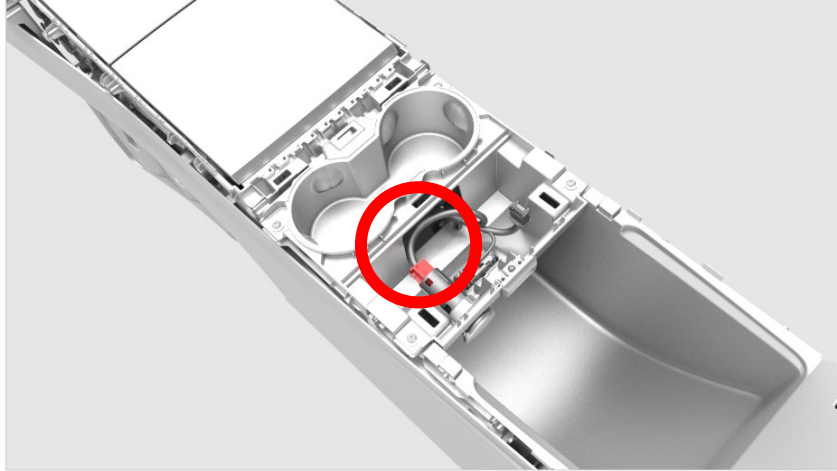

Figure 6

Alternatively, 12V power can be accessed from the gray 3-pin connector (Delphi 12176836) that connects to the 12V auxiliary socket (Figure 7). The blue wire (location A) is positive 12V power and the black wire (location C) is chassis ground.

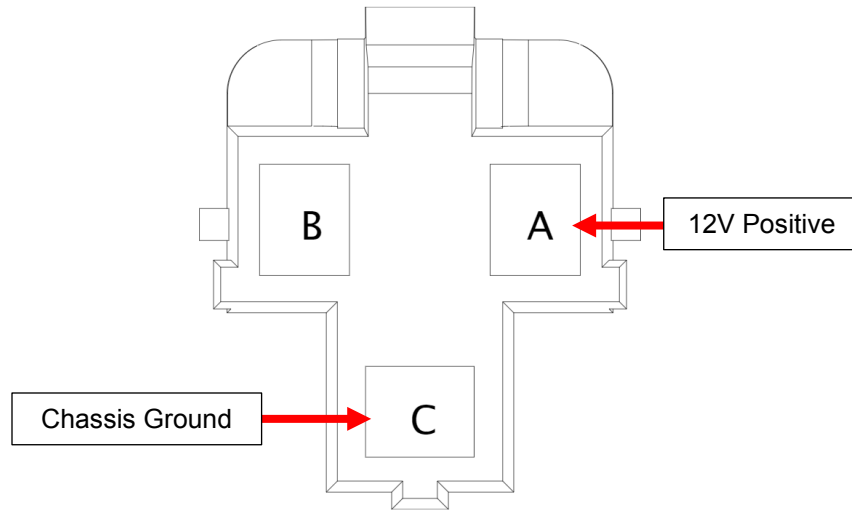



Figure 7

**NOTE:** This power circuit provides up to 12A continuous draw total (16A peak). Consider the electrical requirements of the accessory when deciding how to splice into the circuit. Whenever power is taken from the feeding circuit towards the 12V power socket, the 12V power socket will not be able to provide 12A continuous / 16A peak current anymore.

 **NOTE:** On this circuit, power is available whenever the vehicle is considered "awake". The vehicle may be "awake" for many reasons. For example, when using features such as Summon, or when features such as Cabin Overheat Protection, Keep Climate On, Dog Mode, Sentry Mode, etc. are enabled. The vehicle is also awake whenever the 12V battery is being charged or is in use, during HV charging, when the vehicle is communicating with the mobile app, etc. Leaving an accessory plugged in will not deplete the 12V battery.

 **NOTE:** The 12V power circuit is not protected by a physical fuse. Model 3 monitors current draw and turns off the 12V power supply in case of overcurrent draw. If an overcurrent draw is detected, 12V power will be restored once Model 3 has been powered off and on, assuming the cause of the overcurrent is no longer present. Powering off Model 3 can be done by closing all doors and walking out of range from the vehicle with the phone key for a few seconds or by locking the doors with the key fob or key card and waiting a few seconds.

## Reinstalling Center Console Trim Components

Refer to the following steps for how to reinstall the center console trim components.

1. Reconnect the electrical connector to the security body controller module (Figure 5).

 **CAUTION:** To avoid potential alerts or damage, make sure to connect the security body controller module before reconnecting 12V power.

2. Carefully press down the cup holder décor trim to engage the clips that attach it to the center console (Figure 4).
3. Lower the armrest to close the rear center console compartment.
4. On both sides of the center console, install the screws (x7) (Figure 3) and engage the tabs that attach the bracket to the center console. Tighten the screws to 1.6 Nm (1.18 ft-lbs).
5. On both sides of the center console, engage the clips that attach the center console decor trim to the center console (Figure 2).

## Connecting 12V Power

Refer to Service Manual procedure 17010200 for instructions on reconnecting 12V power.

 **CAUTION:** Failure to properly reconnect 12V power can result in damage to the vehicle or the 12V battery. Tesla is not responsible for any damage to the vehicle or 12V battery.